

# MONOLOCK SYSTEM TOP CASES

## CHECKING THE BOX CONTENTS

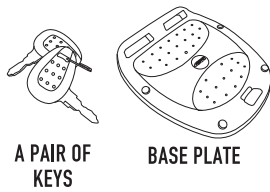

A PAIR OF KEYS

BASE PLATE

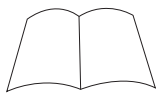

OWNERS' MANUAL  
(THIS GUIDE)

### SCREW SET



4PCS  
M6 ALLEN CAP SCREW

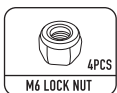

4PCS  
M6 LOCK NUT



4PCS  
SQUARE WASHER



8PCS  
M6 WASHER



2PCS  
CSK STS SCREW

### OPTIONAL

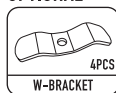

4PCS  
W-BRACKET

## KNOWING YOUR BOX

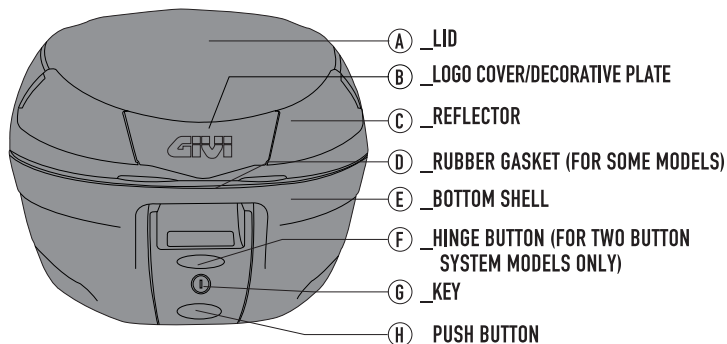

- A \_LID
- B \_LOGO COVER/DECORATIVE PLATE
- C \_REFLECTOR
- D \_RUBBER GASKET (FOR SOME MODELS)
- E \_BOTTOM SHELL
- F \_HINGE BUTTON (FOR TWO BUTTON SYSTEM MODELS ONLY)
- G \_KEY
- H \_PUSH BUTTON

## OPENING AND LOCKING PROCEDURES

### ONE BUTTON SYSTEM

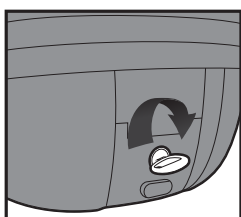

1 \_TURN KEY CLOCKWISE TO UNLOCK.

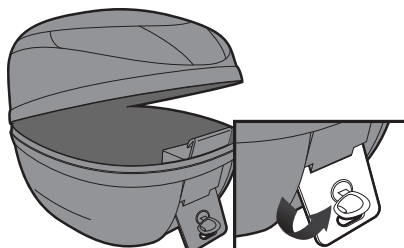

2 \_LIFT HINGE TO OPEN TOP LID.

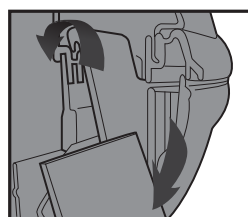

3 \_TO CLOSE LID, ENSURE THAT HINGE IS HOOKED ONTO TOP LID BEFORE LOCKING.

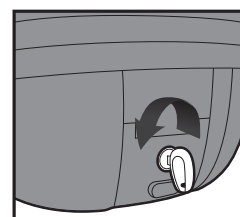

4 \_TURN KEY ANTI-CLOCKWISE TO LOCK.

### TWO BUTTON SYSTEM

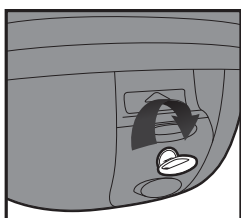

1 \_TURN KEY CLOCKWISE TO UNLOCK.

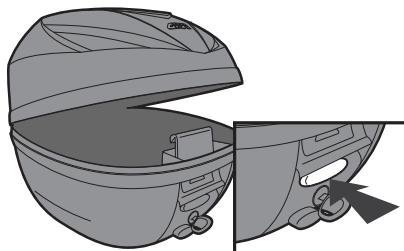

2 \_PRESS HINGE BUTTON TO OPEN AUTOMATICALLY.

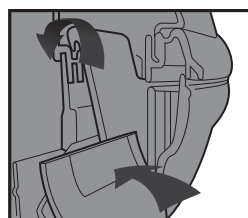

3 \_TO CLOSE LID, ENSURE THAT HINGE IS HOOKED ONTO TOP LID AND PRESS.

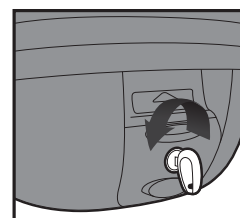

4 \_TURN KEY ANTI-CLOCKWISE TO LOCK.

### TWO BUTTON SYSTEM (EFFORTLESS OPENING AND KEYLESS LOCKING)

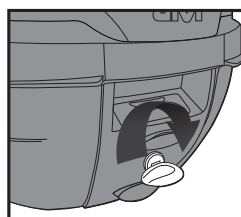

1 \_TURN KEY CLOCKWISE TO UNLOCK.

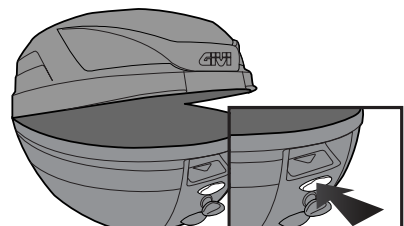

2 \_PRESS HINGE BUTTON TO OPEN THE LID.

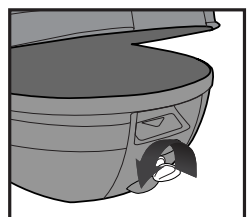

3 \_TURN THE KEY ANTI-CLOCKWISE TO REMOVE THE KEY

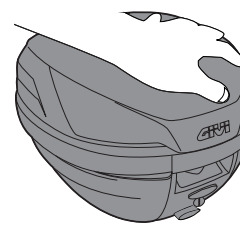

4 \_TO LOCK THE BOX, PRESS DOWN THE LID, ENSURE THERE IS "CLICK" SOUND TO INDICATE THAT IT IS LOCKED.

## ATTACHING AND REMOVING THE BOX

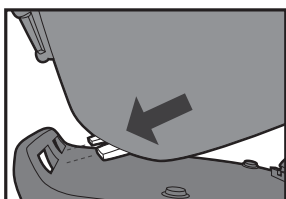

1 \_INSERT PROTRUDING TAB INTO THE BASE PLATE SLOT SECURELY.

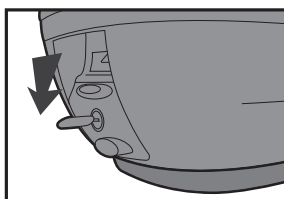

2 \_TO ATTACH BOX, PLACE BOX ONTO BASE PLATE AND PRESS DOWN.

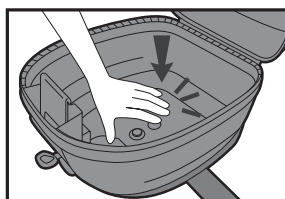

3 \_THERE WILL BE AN AUDIBLE "CLICK" SOUND INDICATING THAT IT IS SECURED.

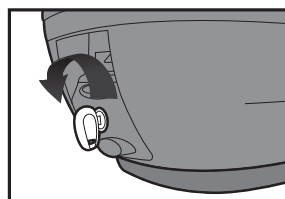

4 \_TURN KEY ANTI-CLOCKWISE TO LOCK.

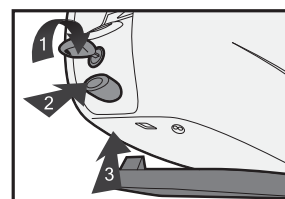

TO REMOVE BOX, TURN KEY CLOCKWISE AND PRESS PUSH BUTTON THEN LIFT BOX.

# MONOLOCK SYSTEM TOP CASES

## WARNING !

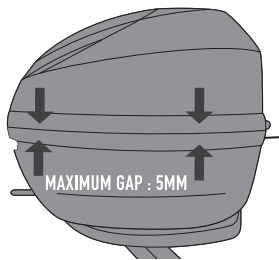

THE ADDITIONAL OF RUBBER GASKET WILL INCREASE THE GAP BETWEEN THE LID AND THE BOTTOM SHELL. HOWEVER IT WILL NOT CAUSE ANY FUNCTIONAL, SAFETY AND RELIABILITY PROBLEM TO THE BOX.

NOTE :  
WHEN OPENING THE TOP LID DO NOT EXTEND MORE THAN 90° AS IT WILL CAUSE THE HINGE TO BREAK.

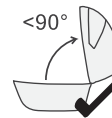

## SAFETY GUIDELINES

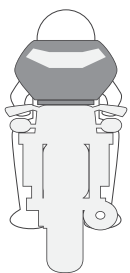

PLEASE TAKE NOTE OF THE FOLLOWING SAFETY GUIDELINES TO AVOID UNNECESSARY RISKS OR DAMAGE TO YOUR MOTORCYCLE. OUR FITTING KITS ARE MADE OF VARIOUS COMPONENTS OF WELDED METALS AND JOINTS WHICH MIGHT POSE ASSEMBLING PROBLEMS DUE TO DIFFERENT CHASIS STRUCTURES.

- RELY ON QUALIFIED MECHANICS TO INSTALL THE FITTING KITS.
- CHECK BIKE FOR FRAME DAMAGE OR BENDING BEFORE INSTALLING.
- COMPONENTS DO NOT INTERFERE OR OBSTRUCT THE FUNCTIONS OF : SHOCK ABSORBERS / CHAINS AND SPROCKETS / SILENCERS ETC.
- DO NOT REUSE DAMAGED CASES OR FITTING KITS.
- NEVER MODIFY THE ORIGINAL FITTING KITS OR COMPONENTS.
- IF IN DOUBT ALWAYS CONTACT THE MANUFACTURER OR DEALER.
- FOR SAFETY PURPOSE, GIVI BOX MUST BE FITTED TO GENUINE GIVI RACK.

\* WARRANTY COULD BE VOID IF THE BOX IS NOT FITTED TO GIVI GENUINE PARTS.

## SAFETY CHECKS PRE-RIDE

- BEFORE RIDING\_CHECK BOX IS PROPERLY SECURED AND LOCKED BY TUGGING.
- PROCEDURE FOR LOCKING\_SEE PAGE 1.
- DO NOT OVERLOAD\_MAX. 3 KG ALLOWED.
- ALWAYS KEEP THE KEY SECURELY.
- MAXIMUM GROSS WEIGHT WITH PILLION AND LUGGAGE\_DO NOT EXCEED WEIGHT AS RECOMMENDED BY MANUFACTURER.
- MAINTAIN A MAXIMUM SPEED OF 110 KM/HOUR WITH FULL LOAD.
- MOUNTING RACKS\_CHECK FOR LOOSE BOLTS AND NUTS\_MOUNTINGS TIGHT AND SECURE.
- CLEANING TIPS\_DO NOT USE SOLVENTS, PETROL OR CHEMICAL PRODUCTS\_USE WATER AND MILD SOAP.

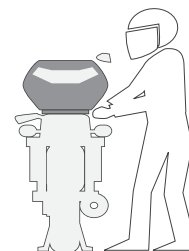

## GIVI'S RACK SYSTEMS

HRV HEAVYDUTY ADVANCE RACK, SR SPECIAL RACK AND SRV SPECIAL ADVANCE RACK SYSTEMS PLAYING AN EQUALLY CRUCIAL ROLE ON THE USE OF GIVI BOXES IS OUR PATENTED HEAVYDUTY RACK SYSTEM. AS ENGINES OF DIFFERENT CAPACITIES EMANATE VARIOUS FREQUENCY LEVELS, SUCH INPUT WILL GENERATE LATERAL THRUST TRIGGERING DEFORMATION ON THE METAL PARTS. EMPLOYING HIGH PRECISION ROBOTIC WELDING MACHINES AND STRICT QUALITY CONTROL ON MATERIAL SPECIFICATION, PRACTICAL CONCERNS SUCH AS DYNAMIC STIFFNESS, STRUCTURAL COMPONENTS AND RELIABILITY ARE FREQUENTLY ADDRESSED AND TESTED THOROUGHLY.



MV MONORACK ADVANCE RACK SYSTEM COMPLEMENTING OUR RANGE OF BASIC RACKING SYSTEMS ARE ANOTHER DERIVATIVE OF OUR PATENTED MOUNTING SYSTEMS THE MV. USING METALS SPECIFIED UNDER CONSTANT RESEARCH BY OUR DEVELOPMENT DEPARTMENT, TENSILE STRENGTH OF THE COMPONENTS, RELIABILITY, ACCURACY AND EASE OF INSTALLATION ARE ALL KEY FACTORS IN THE PRODUCTION OF OUR MV RANGES IN ORDER TO ATTAIN MAXIMUM RESULTS.

TYPES OF RACKS	BOX SYSTEM	BASE PLATE
HRV HEAVYDUTY ADVANCE RACK	MONOLOCK	M5M
SR SPECIAL RACK		MP60N / MP70N
SRV SPECIAL ADVANCE RACK		M5M
MV MONORACK ADVANCE RACK		MP60N / MP70N

\* AS WE CONSTANTLY IMPROVE AND UPGRADE OUR PRODUCTS NEW MODELS WILL SUPERCEDE THE OLDER ONES.